

RELEASE

DATE:

COMPANY:

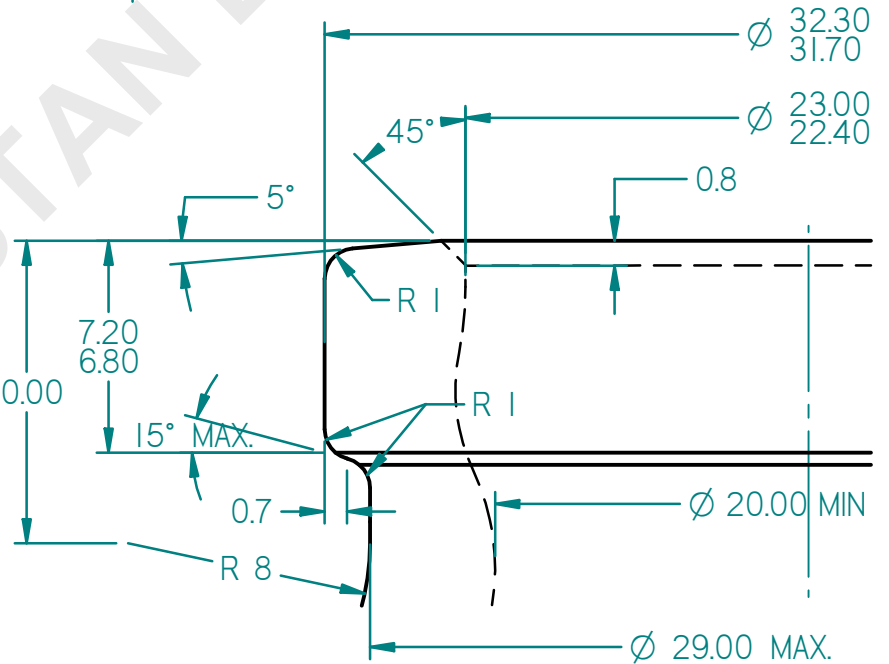
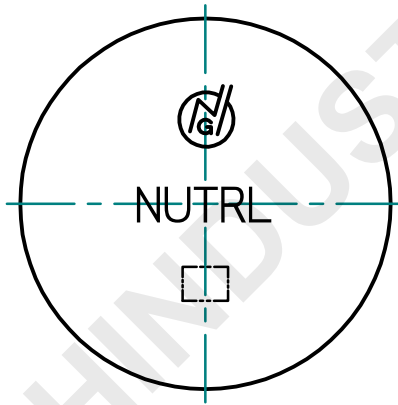
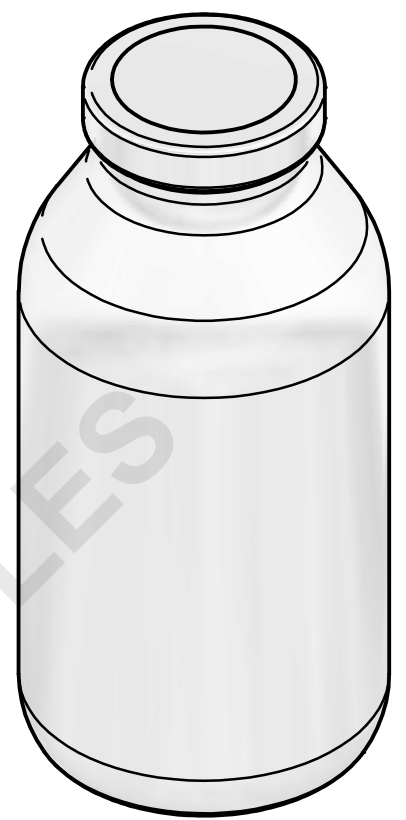
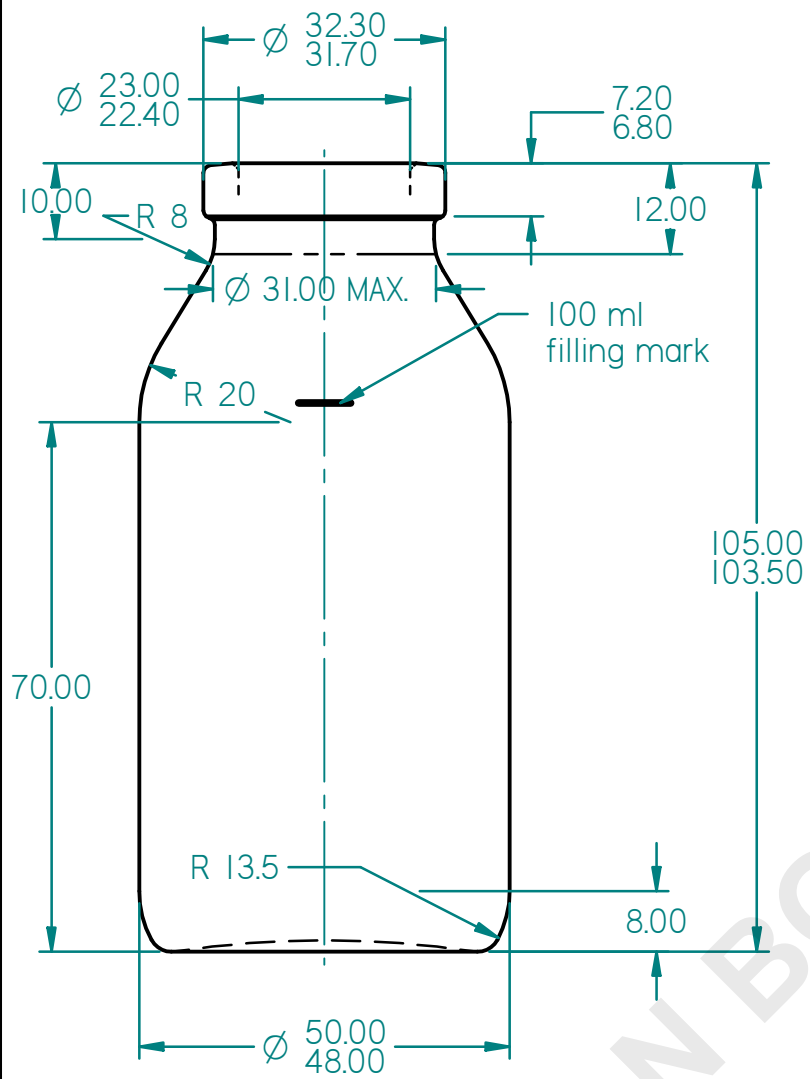

FINISH : 32 mm DIN

Protective note ISO 16016 observed

GENERAL TOLERANCES DIN 6129-1 (DIMENSIONS WITHOUT TOLERANCES ARE FOR REFERENCE ONLY)				FINISH: 32 mm DIN		O'FLOW CAPACITY: 120.0- 130.0 ml		ARTICLE NO.:			
				FINISH DWG: NA		WEIGHT: 98.0 g Approx.		5155161100			
				FINISH MOLD NO: 962		TYPE OF GLASS: I COLOUR: FLINT					
				DATE	NAME	TITLE: 100 ml P/N DIN					
				DRAWN	13.10.2013					dipak	
				CHECKED	13.10.2013					H.B.P.	
				SCALE	1 : 1, 4 : 1						
				GERRESHEIMER NEUTRAL GLASS & ALLIED INDS. PVT. LTD. MUMBAI / KOSAMBA			MOLD NO.:	DRAWING NO.:	REVISION	SHEET	FORMAT
							154	B 5161		0	1 OF 1
REV.				CHANGE	DATE	NAME	FILE: 100 ml DIN.dft				